



Portwell



About Portwell

Who is Portwell, Inc?

Portwell, Inc. founded in 1993, committed to advanced design and engineering expertise in electronics and mechanical with manufacturing integration capability. The effort to adhere to the world-class criteria in every aspect qualified Portwell as a member of the Intel Communications Alliance. With streamline access to the latest Intel technology, we deliver cutting-edge solutions to meet and exceed the demanding needs of market.

Portwell provides system integration development experience, proven expertise in CPU board, Capture card application SDK, chassis, thermal, power, and packaging, to create quality DSS platform with industry grade components for both ISVs and OEM customers.

Why Portwell Develop PVR-1140 with Intel ?

Business Need:

Conventional surveillance systems primarily detect motion and record activity. This isn't enough to guard against today's stealthy terrorist and criminal activities. Intelligent surveillance is needed to detect and prevent harmful events. And since it is not always feasible to use real people in this regard, the security industry needs tools that can supplement human efforts.

Challenge:

The hardware platform needed to support computerized intelligence has a very high-performance threshold. It must be able to process very high-resolution video in real-time over multiple channels. Such video must be simultaneously captured, analyzed and stored, with quick and easy retrieval as needed. It must also be networked so that multiple surveillance systems can be controlled from a central location. Low power consumption is needed for deployment in harsh environments without a fan.

Solution:

Portwell and Intel have developed a digital security surveillance (DSS) platform. The Portwell PVR-1140* uses the Intel® Core™ Duo processor, Intel® 945GM chipset, and other Intel® technologies to meet these performance requirements. With the highest performance at the lowest possible power consumption, the PVR-1140 can be deployed in very brutal situations. It is capable of multithreaded execution to sustain real-time transmission, analysis and storage of massive video data files.



For more information:

Visit the Intel case study at

<http://www.intel.com/design/embedded/casestudies/portwell.pdf>

PORTWELL WINS INTEL® COMMUNICATIONS ALLIANCE AWARD

PVR-1140 takes prize in 2006 Multi-Core Proof Point Contest



Portwell Inc, a leading supplier of Internet Security Appliances, and an Associate Member of the Intel® Communications Alliance, announces that its PVR-1140 industrial grade rackmount digital security surveillance (DSS) platform is the winner in the Intel® Communications Alliance 2006 Multi-Core Proof Point Contest. The award was presented by Intel® at the recent Intel® Communications Alliance Executive Business Connections event held on October 24~26, 2006 in Tucson, Arizona.

"The Portwell PVR-1140 is designed with Intel® Core™ Duo processor and successfully delivers the high computing power and energy saving that is very important in the security industry today," said Jim St. Leger, program

director of Intel® Communications Alliance. "Portwell is a product development leader within our ecosystem and has always evinced strong support for Intel architecture."

PVR-1140 Meets the Need for Proactive Surveillance

"Portwell developed the PVR-1140 because today's surveillance systems need to do more than just detect motion and record activity," explained Thomas Lee, product manager of Portwell. They need to be more intelligent and more proactive to protect against terrorists and criminal activities. And supplement human efforts where using real people are not feasible. Practical usage has proved that Portwell PVR-1140 more than meets these needs.

PVR-1140 Meets the Market Needs

"In order to meet these needs, Portwell designed the PVR-1140 industrial grade rackmount DSS platform," explained Victor Liao, product manager of Portwell. "The PVR-1140 uses the Intel® Core™ Duo processor, Intel® 945GM Express chipset, and other Intel® technologies to meet these performance requirements. Because of its high computing power and low energy consumption, the PVR-1140 can be deployed 24x7 in the very rugged environment. It is capable of multi-threaded execution to sustain real-time transmission, and the analysis and storage of massive video data files."



"Everyone at Portwell is proud that the PVR-1140 won this contest," added Victor, "but we're not resting on our laurels. Portwell is continuously evolving platform solutions based on Intel new technology, and we'll keep providing cutting-edge solutions in the future."



E225600

Features and Compatibility

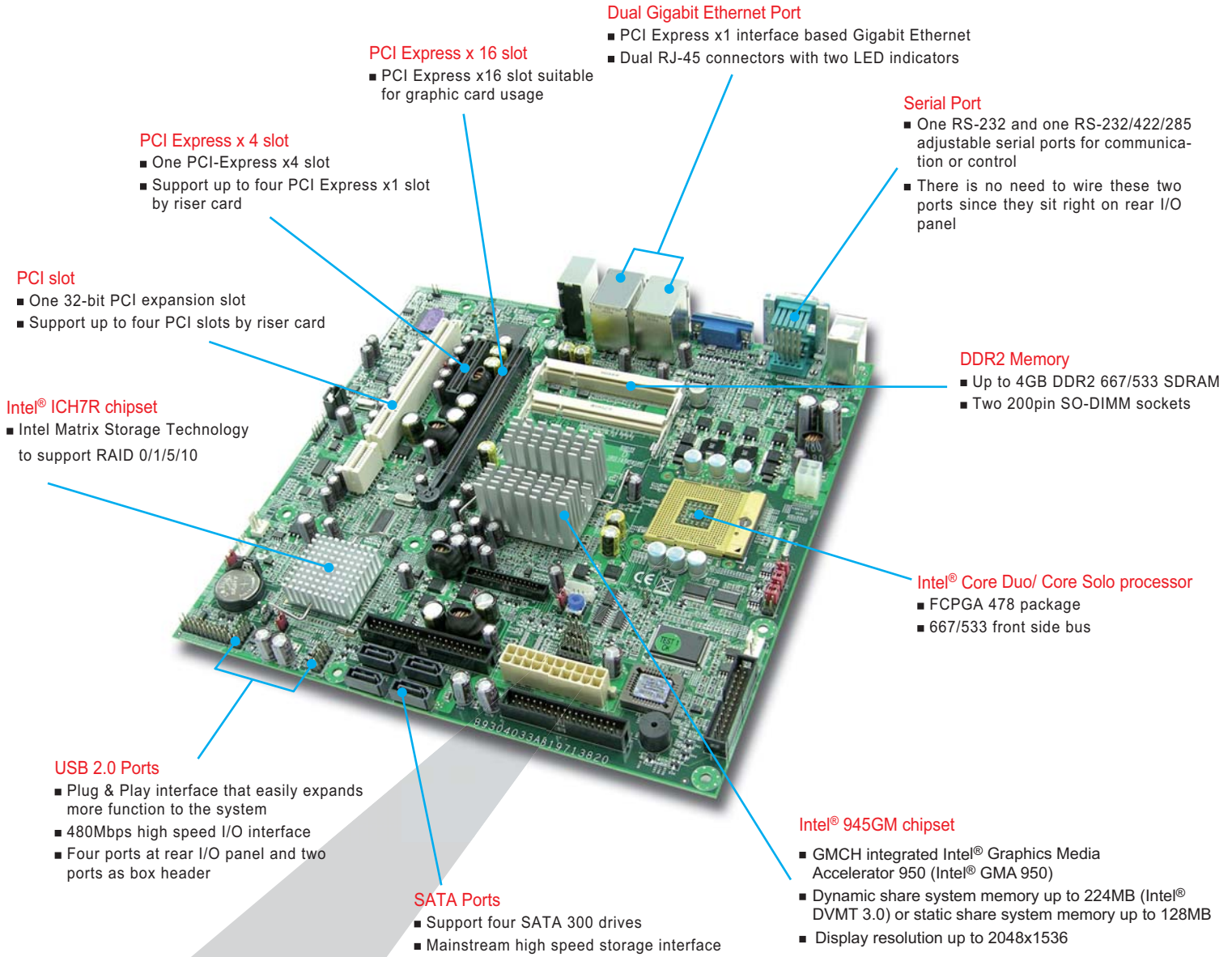

Compatible Processor Table

Brand	Processor Number	Architecture			Clock Speed (GHz)	Front Side Bus (MHz)	L2 Cache	TDP
		Processor Generation	Process	Socket				
Intel® Core™ 2 Duo Processor	T7400	Merom Napa Refresh	65nm	BGA PGA	2.16	667	4MB	34W
Intel® Core™ 2 Duo Processor LV	L7400	Merom Napa Refresh	65nm	BGA	1.5	667	4MB	17W
Intel® Core™ Duo Processor	T2500	Yonah	65nm	BGA PGA	2	667	2MB	31w
Intel® Core™ Duo Processor Low Voltage	L2400	Yonah	65nm	BGA	1.66	667	2MB	15w
Intel® Core™ Duo Processor Ultra Low Voltage	U2500	Yonah	65nm	BGA	1.2	533	2MB	9W
Intel® Celeron® M Processor	530	Merom	65nm	BGA PGA	1.73	533	1MB	27W
	440	Yonah	65nm	BGA* PGA	1.86	533	1MB	27w
Intel® Celeron® M Processor Ultra Low Voltage	423	Yonah	65nm	BGA	1.07	533	1MB	5.5W

RUBY-9713VG2AR

Intel® Core Duo/ Core Solo processor based uATX Industrial Mainboard with DDR2 SO-DIMM, VGA, Dual Gigabit Ethernet, Audio and USB

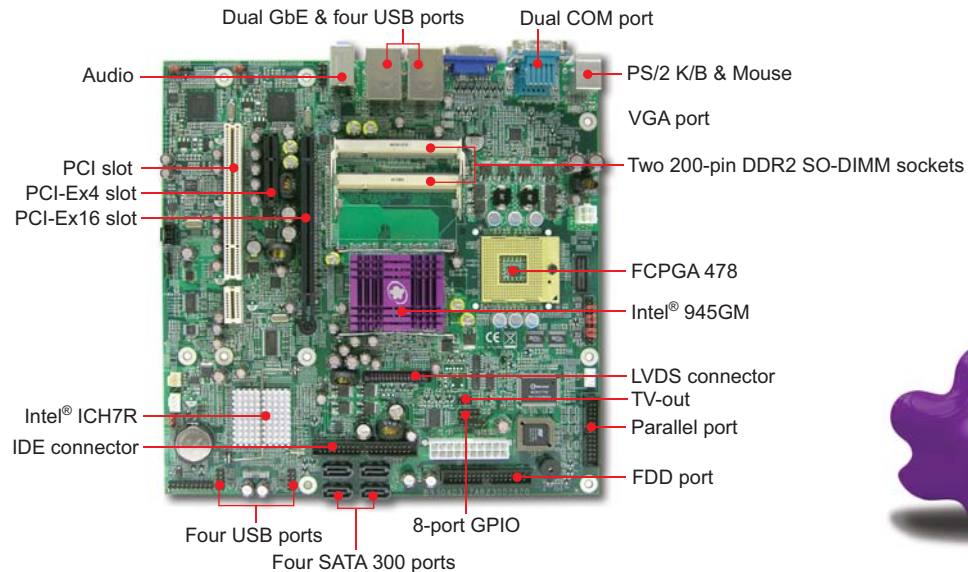

FEATURES

- Industrial mainboard in uATX form factor that supports Intel® Core Duo/ Core Solo processor for MoDT (Mobile on Desktop) application
- One 32-bit PCI expansion slot or support up to four PCI slots by riser card
- One PCI-Express x4 slot or support up to four PCI Express x1 slot by riser card
- Support GPIO, TV-Out and LVDS on board
- Adopts Intel Matrix Storage Technology to support RAID 0/1/5/10
- Dual Gigabit Ethernet ports that based on PCI Express x1 interface without sharing bandwidth of PCI expansion bus
- Optional function: TPM(Trusted Platform Module)1.2 , AMT(Active Management Technology) 1.0

GENERAL

Processor	CPU & Package: Intel® Core Duo/ Core Solo processor FSB: 667/533MHz
Chipset/Core Logic	Intel® 945GM and ICH7R
System Memory	Up to 4GB DDR2 667/533 SDRAM on two 200pin SO-DIMM sockets
BIOS	Award BIOS
Storage Devices	EIDE: Support two EIDE devices with Ultra DMA 100/66/33 SATA: Support four SATA 300 drives RAID : RAID 0/1/5/10
Solid State Disk	N/A
Watchdog Timer	Programmable via software from 0.5 sec. to 254.5 min.
Expansion Interface	- One 32-bit PCI expansion slot or support up to four PCI slots by riser card - One PCI-Express x4 slot or support up to four PCI Express x1 slot by riser card - One PCI-Express x16 slot
Hardware Monitoring	System monitor (fan, temperature, voltage)
Power Requirement	Standby +5@1.7A; +12V(CPU)@3A, +12V(System)@1A, +5V(System)@2.5A, +3.3V(System)@1.5A
Dimension	Dimension: 243.8(L) x 243.8(W) mm ; 9.6"(L) x 9.6"(W) PCB: 6-layer
Environment	Operating Temperature: 0 to 55°C Storage Temperature: -20 to 80°C Relative Humidity: 5% to 90%, non-condensing
MTBF	86,705 hrs

ORDERING GUIDE

Standard	RUBY-9713VG2AR Intel® Core Duo/ Core Solo processor based uATX Industrial Mainboard with DDR2 SO-DIMM, VGA, Dual Gigabit Ethernet, Audio and USB
Optional	PEP-541L PCI-E x 4 to PCI-E x 4 riser card PEP-544L PCI-E x 4 to four PCI-E x 1 riser card PEP-554L PCI to four PCI slots riser card

I/O

MIO	Two serial (RS-232x1, selectable RS-232/422/485x1) One parallel, one FDD channel, eight GPIO
IrDA	IrDA 1.0
Ethernet	-Dual 10BASE-T/100BASE-TX/1000BASE-T Ethernet -PCI Express x1 interface based Gigabit Ethernet -Dual RJ-45 connectors with two LED indicators at rear I/O panel
Audio	AC'97 2.2 Audio
USB	Eight USB 2.0 ports (Four ports at rear I/O panel; four ports internal)
Keyboard & Mouse	Dual 6-pin mini-DIN connector at rear I/O panel for PS/2 keyboard/mouse

DISPLAY

Graphic Controller	GMCH integrated Intel® Graphics Media Accelerator 950 (Intel® GMA 950)
Graphic Memory	Dynamic share system memory up to 224MB (Intel® DVMT 3.0) or static share system memory up to 128MB
Display Interface	Display resolution up to 2048x1536 ; TV-Out, LVDS



FEATURES

- Support Core Duo/ Core Solo processor
- Support PCI-E x 16 slot for Graphic card, PCI-E x 4 slot for RAID card and PCI slot for capture card
- Adopts Intel Matrix Storage Technology to support RAID 0 / 1 / 5 / 10
- Dual Gigabit Ethernet ports

SPECIFICATION

Platform	
CPU	Intel® socket 478 Core Duo or Core Solo processor
Chipset	Intel® 945GM
Memory	Up to 4GB DDR2 667/533 SDRAM on two 200-pin So-DIMM sockets
BIOS	Award
SSD	N/A
Storage Device	4 Swappable HDD
Expansion	1 PCI slot, 1 PCI-Ex4 slot, 1 PCI-Ex16 slot
RAID Function	RAID 0 / 1 / 5 / 10
Operating Temperature	0 to 40°C
Color	Black
Dimension	410(W) x 510(D) x 44(H) mm
Optional	N/A
I/O	
MIO	Two serial (RS-232 x 1, selectable RS-232/422/485x 1)
Ethernet	Dual 10BASE-T/100BASE-TX/1000BASE-T
Audio	AC '97 2.2
Keyboard/Mouse	PS/2
GPIO	N/A
USB	USB2.0 x 4

■ PVR-1140 Drawing

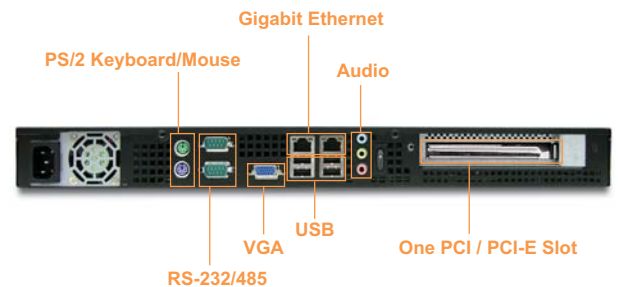

Display	
Chipset	Intel® GMA950 GMCH
Display Memory	Dynamic share system memory up to 224MB or static share system memory up to 128MB
Interface	VGA

* Specifications are subject to change without notice.

* Celeron®, Pentium® III, Pentium® 4 and Xeon™ are registered trademarks of Intel® Corporation

* Other trademarks, logo, brands and company names are the property of their respective owners



Portwell, Inc. (Headquarters)
 3F, No. 92, Sec. 1, Nei-Hu Rd.,
 114 Taipei, Taiwan
 Tel: +886-2-27992020
 Fax: +886-2-27991010
 E-mail: info@portwell.com.tw
 http://www.portwell.com.tw

American Portwell
 44200 Christy St.
 Fremont, CA 94538, USA
 Tel: +1-510-403-3399
 Fax: +1-510-403-3184
 E-mail: info@portwell.com
 http://www.portwell.com

Portwell Japan, Inc.
 〒101-0042 ShowaKanda Build, 10-2
 Kanda Higashi matsushita-cho
 chiyoda-ku Tokyo Japan
 Tel: +81-3-5298-8071
 Fax: +81-3-5298-8072
 E-mail: info@portwell.co.jp
 http://www.portwell.co.jp

Beijing Portwell
 6F, Building 3, Qunying Zone,
 Chuangye Rd. 8, Shangdi, Haidian
 District, Beijing, China 100085
 Tel: +86-10-82701616
 Fax: +86-10-82700606
 E-mail: info@portwell.com.cn
 http://www.portwell.com.cn

Portwell (UK) Ltd.
 Unit 7, Holloways, Bessemer Close
 Ebblake Industrial Estate, Verwood,
 Dorset, BH31 6AZ, UK
 Tel: +44(0)1202-813816
 Fax: +44(0)1202-813817
 E-mail: info@portwell.co.uk
 http://www.portwell.co.uk

Portwell-Laxsons India
 Laxsons House, AA2, Walbhat Road,
 Goregaon (E), Mumbai - 400 063,
 Maharashtra, India.
 Tel: +91-22-2685-9911
 Fax: +91-22-2685-9922
 E-mail: info@portwellaxsons.com
 http://www.portwellaxsons.com