

No Limit Bandwidth



Ver. 26E

Portwell
Together in Electric Dream!

PICMG (PCI Industrial Computer Manufactures Group) 1.0/1.2



Back to 1994, PICMG released the PICMG 1.0 PCI/ISA specification that separates expansion slot as backplane from mainboard and turns key parts of mainboard into Single Board Computer. This special form factor features lower mean time to repair (MTTR), easy to upgrade, more expansion slots for ISA and PCI add-in cards.

After few years, PICMG released PICMG 1.2 in 2002, which removed support of ISA and moved component side to follow PCI orientation. And the dual expansion bus could be any combination of PCI and PCI-X, therefore, the important message unveils the tremendous decreasing of ISA cards and higher I/O bandwidth requirement of applications.

PCI Express Introduction

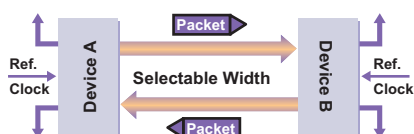

Figure 1: A PCI Express link uses transmit and receive signal pairs

Year 2003, Intel® launched her first PCI Express chipset that drawn everybody's attention. What is PCI Express? PCI Express, previously called 3GIO (3rd Generation I/O) was created to keep the pace with faster processor for balanced data streaming. It moves from the earlier PCI single parallel data bus to an assembly of serial, multiple point-to-point wired and individually clocked lanes.

A Link represents a dual-simplex communications channel between two devices. The fundamental PCI Express Link consists of two, low-voltage, differentially driven signal pairs: a Transmit pair and a Receive pair. Once initialized, each Link must operate at one of the supported signaling levels.

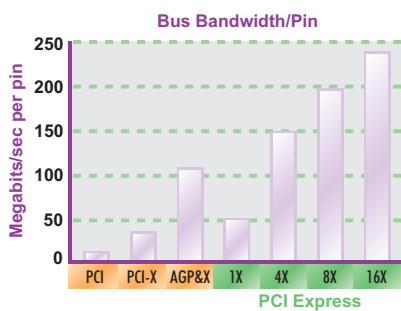

Figure 2: Comparison of I/O Bus Bandwidth Per Pin

For the first generation of PCI Express technology, there is only one signaling rate defined, which provides an effective 2.5 Gigabits/second/Lane/direction of raw bandwidth. Multiple Lanes may aggregate for scalable bandwidth, and denoted by xN where N may be any of the supported Link widths. The PCI Express Base Specification Revision 1.0a addressed operations for x1, x2, x4, x8, x12, x16 and x32 Lane. The bandwidth of an x8 Link for example is 20 Gigabits/second of raw material in each direction.

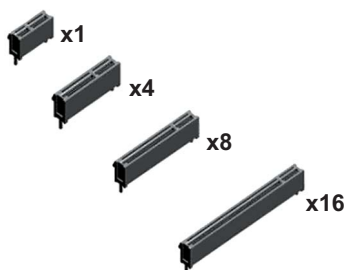

Figure 3: Mechanical drawings of different PCI Express slots

Bandwidth of PCI, PCI-X, and AGP Buses

Bus and Frequency	Peak 32-Bit Transfer Rate	Peak 64-Bit Transfer Rate
33-MHz PCI	133 MB/sec	266 MB/sec
66-MHz PCI	266 MB/sec	532 MB/sec
100-MHz PCI-X	Not applicable	800 MB/sec
133-MHz PCI-X	Not applicable	1 GB/sec
AGP8X	2.1 GB/sec	Not applicable

PCI Express Bandwidth

PCI Express Implementation	Encoded Data Rate	Unencoded Data Rate
x1	5 Gbps	4 Gbps (500 MB/sec)
x4	20 Gbps	16 Gbps (2 GB/sec)
x8	40 Gbps	32 Gbps (4 GB/sec)
x16	80 Gbps	64 Gbps (8 GB/sec)

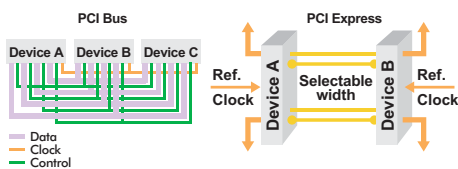

Figure 4: PCI & PCI Express architecture comparison

Benefit of PCI Express is not only bandwidth, advantages such like low pin count (small slot); software compatible with PCI & PCI-X (no need special OS); built-in QoS (prioritize quality of service); support both internal and external expansion (designed for chip-to-chip, SHB-to-backplane, or box-to-box interconnection) are factors that helping its quickly growth.

PICMG 1.3 (SHB Express™) Overview

As a solution, PICMG organization started development of new standard in last year that adopts PCI Express as external expansion.

- PICMG 1.3, so called "SHB Express" takes component side as ISA card that means it is the same as PICMG 1.0. Such setting makes signal routing among processor, memory controller hub and memory is more smoothly and it can leverage chassis design for PICMG 1.0.
- Same as PICMG 1.2 (ePCI-X), SHB Express defined both full-size and half-size SHB.
- Slot for full-size SHB is combination of dual PCI Express x16 (Connector A & C) and dual PCI Express x8 slots (Connector B & D); one PCI Express x16 (Connector A) and one PCI Express x8 (Connector B) for half-size SHB. Therefore, this new standard does not compatible with either PICMG 1.0 or 1.2.
- Electrical Function of edge connectors:
 - Connect A & B: PCI Express Link; configuration could be one x16 or two x8 or one x8 and two x4 or four x4
 - Connect C & B: Additional power and I/O
 - Connect D: One 32-bit PCI(-X) bus
- More +12V power input pins are defined in PICMG 1.3 because new Intel Pentium 4 processor consumes more than 100W and the efficiency is lower for utilized +5V transformation. By the way, 20A up current leads transformation circuit generating more heat; therefore, life-time of the SHB will decrease accordingly.
- Insertion loss of serial type signals are also limited in the specification due to the edge connectors is break point of impedance, therefore, serial type signal has reflection and attenuation issues.
- Miscellaneous I/O ports such as USB, SATA and Gigabit Ethernet can be routed to backplane that features more reliable signal quality and minimum length of cables.
- IPMB (Intelligent Platform Management Bus) and SMBus are also reserved for connection of system management possibility

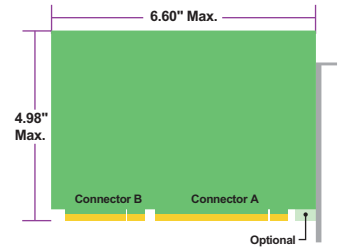

Figure 5: Dimension drawing of half-size SHB

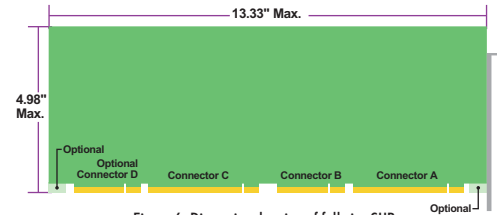

Figure 6: Dimension drawing of full-size SHB

Table: PCIe Link Configurations

Configuration	A0 (x16)				Ref Clks for all Ports (up to 8 Clks)	A0 (x4)			
	A2 (x8)		A0 (x8)			B3 (x1)	B2 (x1)	B1 (x1)	B0 (x1)
	A3 (x4)	A2 (x4)	A1 (x4)	A0 (x4)					
c1	x16				(Ref Clks)	x4			
c2	second x8		first x8		(Ref Clks)	x4			
c3	third x4	second x4	x8		(Ref Clks)	first x4			
c4	fifth x4	fourth x4	third x4	second x4	(Ref Clks)	first x4			

A backplane should plumb the PCIe in the following order to maximize interoperability:

c5	8th	7th	6th	5th	4th	3rd	2nd	1st
----	-----	-----	-----	-----	-----	-----	-----	-----

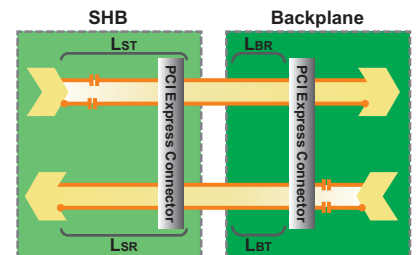
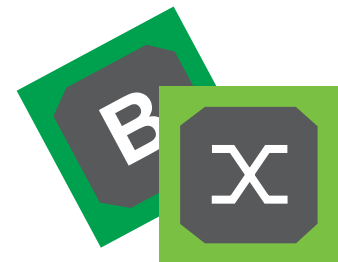

Figure 8: PCIe Insertion loss

Backplane Features

Off course, higher I/O bandwidth is introduced by this new form factor. Take, for example, applications like flight simulation, gaming, medical are need high performance graphics engine. In past, both PICMG 1.0 & 1.2 are not support AGP port on backplane. So, the only solution is having the graphics controller on-board. However, space and thermal constrain the power of graphics engine. For these applications, PICMG 1.3 is the solution that allows system to include latest and mighty graphics add-in card with PCI Express x16 interface.

PCI Express x16 graphics card utilization is just one merit of SHB Express standard. More than that, versatile backplane could fulfill your special requirement immediately. With native expansion interfaces that support by SHB, switch or bridge can be design-in to have more PCI Express slots or different kind of expansion bus such as PCI-X and PCI.



ROBO-8910VG2A

Intel® Pentium® 4 or Celeron® D processor based PICMG 1.3 SHB with DDR2 533 SDRAM, VGA, Dual Gigabit Ethernet and Audio

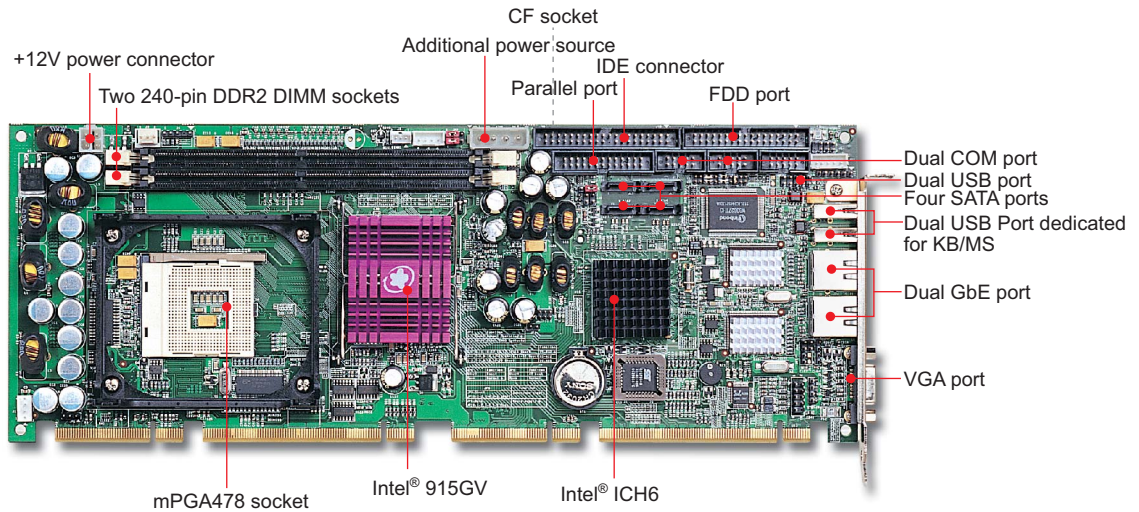

FEATURES

- High quality and reliable design for wider range Intel® Pentium® 4/Celeron® D processor support mission critical operation
- Intel® 915GV chipset with high performance integrated graphics, backed up by Intel® IPD's long product life support
- Intel® new integrated engine GMA 900 provides better display quality and effects thru faster engine and SGI OpenGL 1.4, Microsoft DirectX 9.0 support
- Four SATA 150 ports for high speed storage interface and easy routing of cable
- Support four PCI Express x1, and four PCI expansion via backplane (additional one PCI Express x16 by project based)

ORDERING GUIDE

Standard	ROBO-8910VG2A Socket 478 Pentium® 4 or Celeron® D processor based PICMG 1.3 SHB with DDR2 SDRAM, VGA, Dual Gigabit Ethernet and Audio
Optional	PA-M1AU Multimedia kit with audio and dual USB port PS/2 Keyboard/Mouse with Bracket PS/2 keyboard/mouse connectors on bracket

GENERAL

Processor	CPU & Package: Intel® Pentium® 4 or Celeron® D processor in the mFCPGA package FSB: 800/533MHz
Chipset/Core Logic	Intel® 915GV and ICH6
System Memory	Up to 2GB DDR2 533/400 SDRAM on two 240-pin DIMM sockets
BIOS	Award BIOS
Storage Devices	EIDE: Support two EIDE devices with Ultra DMA 100/66/33 SATA: Support four SATA 150 drives
Solid State Disk	- One type II CF socket on primary EIDE channel - Bootable for no drive on primary channel
Watchdog Timer	Programmable via software from 0.5 sec. to 254.5 min.
Expansion Interface	- Four PCI Express x1 - Four PCI
Hardware Monitoring	System monitor (fan, temperature, voltage)
Power Requirement	Typical: +5V@3.49A; +12V@7.57A
Dimension	Dimension : 338.5(L) x 126.39(W) mm; 13.33"(L) x 4.98" (W) PCB: 8-layer
Environment	Operating Temperature: 0 to 60°C Storage Temperature: -20 to 80°C Relative Humidity: 5% to 90%, non-condensing
MTBF	115,533 hrs

I/O

MIO	Two serial(selectable RS232/422/485 x1), one parallel
IrDA	IrDA1.0
Ethernet	- Dual 10BASE-T/100BASE-TX/1000BASE-T Ethernet - Dual RJ-45 connectors with two LED indicators
Audio	AC'97 2.2 Audio
USB	Eight USB 2.0 ports (four ports through backplane)
Keyboard & Mouse	Two USB 2.0 ports on bracket for keyboard & Mouse

DISPLAY

Graphic Controller	915GV integrated Graphics Media Accelerator 900 (GMA 900)
Graphic Memory	Dynamic share system memory up to 224MB (Intel® DVM 3.0) or static share system memory up to 128MB
Display Interface	Display resolution up to 2048x1536 @ 85Hz refresh

ROBO-8911VG2A

Intel® Pentium® M or Celeron® M processor based PICMG 1.3 SHB with DDR2 SDRAM, VGA, Dual Gigabit Ethernet and Audio

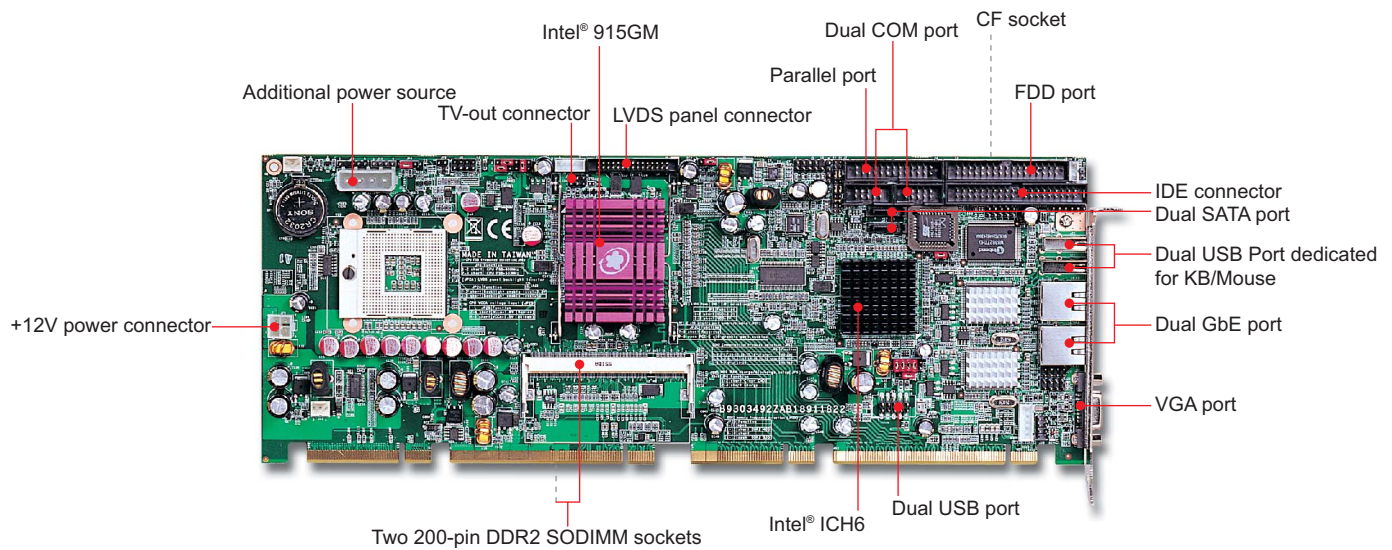

FEATURES

- ROBO-8911 offers flexible 400MHz and 533MHz FSB selection of Intel® Pentium® M / Celeron® M that features high computing power with low heat
- Intel® new integrated engine GMA 900 provides better display quality and effects thru faster engine and SGI OpenGL 1.4, Microsoft DirectX 9.0 support or adapts the latest external PCI Express x16 interface graphics card via backplane
- Support dual view function via VGA, LVDS and TV interfaces
- Four SATA 150 ports for high speed storage interface and easy routing of cable (project based support RAID 0, 1 or Intel® Matrix Storage)
- Support four PCI Express x1, one PCI Express x16 and four PCI expansion via backplane

GENERAL

Processor	CPU & Package: Intel® Pentium M or Celeron M processor in the mFCPGA package FSB: 533/400MHz
Chipset/Core Logic	Intel® 915GM and ICH6
System Memory	Up to 2GB DDR2 533/400 SDRAM on two 200-pin SODIMM sockets
BIOS	Award BIOS
Storage Devices	EIDE: Support two EIDE devices with Ultra DMA 100/66/33 SATA: Support four SATA 150 devices (two through backplane)
Solid State Disk	One Type II CF socket on primary EIDE channel
Watchdog Timer	Programmable via software from 0.5 sec. to 254.5 min.
Expansion Interface	- One PCI Express x16 - Four PCI Express x1 - Four PCI
Hardware Monitoring	System monitor (fan, temperature, voltage)
Power Requirement	Typical: +5V@3.1A; +12V@1.2A
Dimension	Dimension : 338.5(L) x 122(W) mm; 13.33"(L) x 4.8" (W) PCB: 8-layer
Environment	Operating Temperature: 0 to 60°C Storage Temperature: -20 to 80°C Relative Humidity: 5% to 90%, non-condensing
MTBF	91,855 hrs

ORDERING GUIDE

Standard	ROBO-8911VG2A Socket mPGA479M Pentium® M or Celeron® M processor based PICMG 1.3 SHB with DDR2 SDRAM, VGA, Dual Gigabit Ethernet and Audio
Optional	PA-M1ATU Multimedia kit with audio, TV-out and USB ports PS/2 Keyboard/Mouse with Bracket PS/2 keyboard/mouse connectors on bracket

I/O

MIO	Two serial (selectable RS232/422/485 x1), one parallel
IrDA	IrDA 1.0
Ethernet	- Dual 10BASE-T/100BASE-TX/1000BASE-T Ethernet - Dual RJ-45 connector with two LED indicators
Audio	AC'97 2.2 Audio
USB	Eight USB 2.0 ports (four through backplane)
Keyboard & Mouse	Two USB 2.0 ports on bracket for keyboard & mouse

DISPLAY

Graphic Controller	915GM Integrated Graphics Media Accelerator 900 (GMA 900)
Graphic Memory	Dynamic share system memory up to 224MB (Intel® DVMT 3.0) or static share system memory up to 128MB)
Display Interface	CRT: Up to 2048x1536 mode LVDS: Single/Dual 18-bit LVDS channel support TV: Up to 1024x768 resolution supported for NTSC/PAL

AREMO-4185

19" 4U industrial rack-mount chassis

GENERAL

Construction	Heavy-duty steel with aluminum front panel
Drive Bay	External: 5.25"x3 Internal: 3.5" HDD x2
Card Retainer	Three locations for one card retainer
Air Filter	One front replaceable air filter
Cooling Fan	One 12 cm and one 8 cm ball-bearing cooling fans
Indicator	Power on/off x1, HDD x1
Switch	Power on/off x1, System reset x1
Speaker	One 8 Ω speaker
Connector	Four USB ports on the front panel
Standard Color	Silver, Black
Dimension	482(W) x 461(D) x 177(H) mm; 19"(W) x 18.1"(D) x 7"(H)
Weight	Net: 13.5 kg; Gross: 14.5 kg (32 lb)

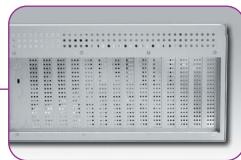

PBPE-13A8 Top View

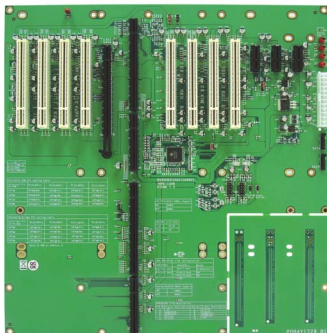

PBPE-13A8 Block Diagram

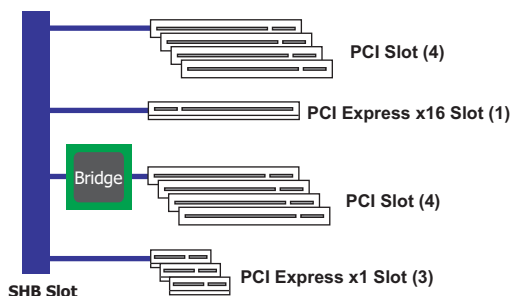

ORION-D4601NP



BACKPLANE

PBPE-13A8

Expansion	- 1-slot PCI Express x16 - 8-slot PCI (dual PCI bandwidth) - 3-slot PCI Express x1
MIO	- Four USB ports - Dual SATA port
Power	24-pin ESP12V power connector

POWER SUPPLY

ORION-D4601NP

Input Voltage	90V ~ 264V AC, full range
Input Frequency	47 ~ 63 Hz
Input Current	9A@115V, 5A@230V
Efficiency	>60%
Holdup Time	16 ms at full load
Over Voltage Protection	+5V@5.7 ~ 7.0V; +3.3V@3.9 ~ 4.5V; +12V@13.6 ~ 16.0V
Over Power/Load Protection	Output power over 110% ~ 150%
MTBF	100,000 hrs
EMI & Safety Approval	UL, cUL, TUV, CE, FCC
Temperature/Humidity	Operating: 0 ~ 40°C, 20 ~ 90%RH Storage: -20 ~ 60°C, 5 ~ 95%RH
Dimension	150(W) x 140(D) x 86(H) mm; 5.9"(W) x 5.5"(D) x 3.4"(H)

ENVIRONMENT

Operating Temperature Range	0 to +55°C
Storage Temperature Range	0 to +70°C
Relative Humidity	5% to 95%, non-condensing
Vibration	5~7 Hz: 0.5" double amplitude displacement 7~2000 Hz: 1.5g acceleration

AREMO-2173EA 19" 2U industrial rack-mount chassis

GENERAL

Construction	Heavy-duty steel
Drive Bay	External: Slim type CD-ROM x1, front accessible 3.5" HDD x2
Air Filter	One front replaceable air filter
Cooling Fan	Two 8 cm ball-bearing fans
Indicator	Power on/off x1, HDD x1
Switch	Power on/off x1 (with a protection cap) System reset x1
Speaker	One 8 Ω speaker
Connector	Two USB ports equipped on the front panel
Standard Color	Silver, Black
Dimension	482(W) x 441.6(D) x 88.4(H) mm; 19"(W) x 17.4"(D) x 3.5"(H)



PBPE-06V Left/Right View

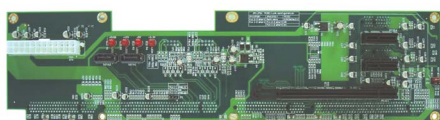

Left View

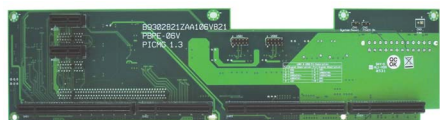

Right View

PBPE-06V Block Diagram

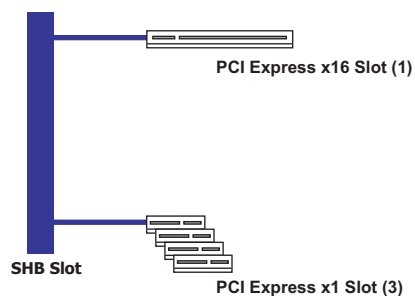

ORION-D3501P



BACKPLANE

PBPE-06V

Expansion	- 1-slot PCI Express x16 - 4-slot PCI Express x1*
MIO	- Four USB ports - Dual SATA port
Power	24-pin ESP12V power connector

*: Only 3-slot PCI-Express x1 available in AREMO-2173EA

POWER SUPPLY

ORION-D3501P

Input Voltage	90V ~ 264V AC, full range
Input Frequency	47 ~ 63 Hz
Input Current	6A@90V
Efficiency	>68%
Holdup Time	17 ms at full load@25°C
Over Voltage Protection	+5V@7V; +3.3V@4.3V; +12V@15.6V
Over Power/Load Protection	Output power over to 110% ~ 140%
MTBF	75,145 hrs
EMI & Safety Approval	UL, TUV, CE, FCC, CB, CSA, SEMKO, FIMKO NEMCO, DIMCO
Temperature/Humidity	Operating: 0 ~ 50°C, 20 ~ 85%RH Storage: -40 ~ 70°C, 10 ~ 90%RH
Dimension	150(W) x 140(D) x 86(H) mm; 5.9"(W) x 5.5"(D) x 3.4"(H)

ENVIRONMENT

Operating Temperature Range	0 to +50°C
Storage Temperature Range	-40 to +70°C
Relative Humidity	5% to 95%, non-condensing
Vibration	5~7 Hz: 0.5" double amplitude displacement 7~2000 Hz: 1.5g acceleration

Design & Manufacturing Service

Since PICMG 1.3 is brand new standard, so there are not so many backplane and systems on the market for your choice. However, the powerful SHB Express can have versatile expansion thru the high-speed I/O interface - PCI Express.

As mentioned above, the expansion could be native PCI Express and PCI supported by SHB or more PCI Express link that extended by switch, PCI-X that extended by bridge. For different applications, those expansion interface and slot number could vary accordingly. As a result, exist backplane or even chassis that designed for PICMG 1.0 may not adequate.

Portwell is the leading company who provide not only boards and backplane of PICMG 1.x but also chassis and power supply. Having kernel SHB of PICMG 1.3 that Portwell provided, we can easily develop backplane and system dedicated to your needs.

The customized backplane can be created within 45 working days and modified chassis that based on portfolio of Portwell chassis once the specification settled down.

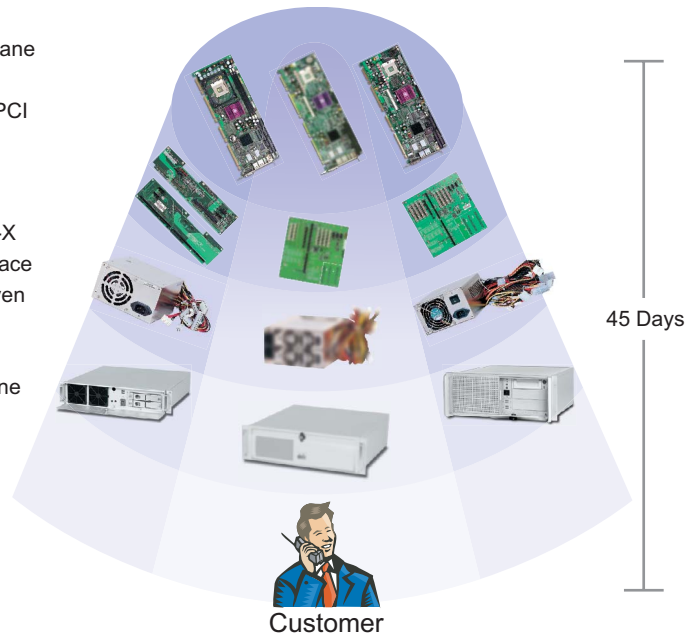

PICMG 1.3 Selection Guide

Chassis		AREMO-2173EA	AREMO-4185
Form Factor		19" 2U Rack-Mount	19" 4U Rack-Mount
Drive Bay	External	3.5" HDD x2 + Slim CD-ROM x1	5.25" x 3
	Internal	N/A	3.5" HDD x 2
Cooling Fan		8cm x 2	8cm x 1; 12cm x 1
Indicator		Power on/off x 1 HDD x 1	Power on/off x 1 HDD x 1
Switch		Power on/off x 1 System reset x1	Power on/off x 1 System reset x1
Air Filter		Front exchangeable	Front exchangeable
Connector		Two USB ports on the front panel	Four USB ports on the front panel
Standard Color		Sliver, Black	Sliver, Black
Dimension		482(W) x 441.6(D) x 88.4(H) mm	482(W) x 461(D) x 177(H) mm
Backplane		PBPE-06V	PBPE-13A8
SHB Slot		1	1
PCI Slot		N/A	8
PCI Express x1 Slot		3	3
PCI Express x16 Slot		1	1
Power Connector		24-pin ESP12V	24-pin ESP12V
Dimension		84mm x 331.94mm	292.59mm x 327mm
Power Supply		ORION-D3501P	ORION-D4601NP
Watt		350W	460W
Input Voltage		90V~264V AC, Full-range	90V~264V AC, Full-range
Input Frequency		47~63Hz	47~63Hz



Portwell, Inc. (Headquarter)
 3F, No. 92, Sec. 1, Nei-Hu Rd.,
 114 Taipei, Taiwan
 Tel: +886-2-27992020
 Fax: +886-2-27991010
 E-mail: info@portwell.com.tw
 http://www.portwell.com.tw

American Portwell
 44200 Christy St.
 Fremont, CA 94538, USA
 Tel: +1-510-403-3399
 Fax: +1-510-403-3184
 E-mail: info@portwell.com
 http://www.portwell.com

Portwell Japan, Inc.
 ☎011-0042 ShowaKanda Build, 10-2
 Kanda Higashi matsushita-cho
 chiyoda-ku Tokyo Japan
 Tel: +81-3-5298-8071
 Fax: +81-3-5298-8072
 E-mail: info@portwell.co.jp
 http://www.portwell.co.jp

Portwell-Laxsons India
 Laxsons House, AA2, Walbhat Road,
 Goregaon (E), Mumbai - 400 063,
 Maharashtra, India.
 Tel: +91-22-2685-9911
 Fax: +91-22-2685-9922
 E-mail: info@portwelllaxsons.com
 http://www.portwelllaxsons.com

Beijing Portwell
 6F, Building 3, Quanying Zone,
 Chuangye Rd. 8, Shangdi, Haidian
 District, Beijing, China 100085
 Tel: +86-10-82701816
 Fax: +86-10-82700606
 E-mail: info@portwell.com.cn
 http://www.portwell.com.cn

EMCA (UK)
 Unit 30, Basepoint Enterprise Centre
 Stroudley Road, Basingstoke,
 Hampshire, RG24 8UP UK
 Tel: +44-1256-406688
 Fax: +44-1256-406689
 E-mail: info@emca.co.uk
 http://www.emca.co.uk